

2000425 Series Liquid Turbine Flow Meter

Operation Manual

I . Overview

2000425 series turbine flow sensors (hereinafter referred to as the sensor) is based on the principle of torque balance and belongs to the speed type flow meter. The sensor has the characteristics of simple structure, light weight, high precision, good repeatability, sensitive response, easy installation and maintenance. It can be used in petroleum, chemical industry, metallurgy, water supply, papermaking and other industries. It is an ideal instrument for flow measurement and energy saving.

The sensor is suitable for measuring the liquid in the closed pipeline that does not corrode with stainless steel 1Cr18Ni9Ti, 2Cr13, corundum Al₂O₃, hard alloy, and has no impurities such as fibers and particles. When it is paired with data acquisition instruments, it can perform quantitative control and over-quantity alarm.

The sensor is suitable for medium with a viscosity less than $5 \times 10^{-6} \text{m}^2 \text{s}^{-1}$ at the working temperature.

II . 2000425 turbine flow sensors

1. Structural features and working principle

(1) Structural features

The sensor is a thrust type of hard alloy bearing, which not only ensures accuracy and improves the wear resistance, but also has

the characteristics of simple structure, firmness and convenient disassembly and assembly.

(2) Working principle

The fluid flows through the sensor housing. Since the blades of the impeller have a certain angle with the flow direction, the impulsive force of the fluid makes the blades have a rotational torque. After overcoming the frictional torque and fluid resistance, the blades rotate, and the speed is stable after the torque is balanced. Under certain conditions, the rotation speed is proportional to the flow velocity. Because the blade has magnetic permeability, it is in the magnetic field of the signal detector (composed of permanent magnet steel and coil). The rotating blade cuts the magnetic field line and periodically changes the magnetic flux of the coil, so that the two ends of the coil induce an electric pulse signal, which is amplified and shaped by the amplifier to form a continuous rectangular pulse wave with a certain amplitude, which can be transmitted to data acquisition instrument remotely to log the instantaneous flow or total amount of the fluid.

Instrument caliber (mm)	Standard flow range (m ³ /h)	Extended Flow Range (m ³ /h)
DN4	0.04~0.25	0.04~0.4
DN6	0.1~0.6	0.06~0.6
DN10	0.2~1.2	0.15~1.5
DN15	0.6~6	0.4~8
DN20	0.8~8	0.45~9
DN25	1~10	0.5~10
DN32	1.5~15	0.8~15
DN40	2~20	1~20
DN50	4~40	2~40

Typical instrumentation coefficients and frequency bands

Instrument caliber (mm)	Instrument coefficient (Times/L)	Frequency band (Hz)
DN4	19000	177.8-1111
DN6	8450	227.8-1366
DN10	1700	100.0-600
DN15	820	138.3-1383
DN20	375	80-800
DN25	212	58.9-588
DN32	150	62.5-625
DN40	75	42.8-427
DN50	27	30.0-300

Basic parameters and technical performance

(1) Selection parameters ;

Type	2000 425								Liquid Turbine Flow Meter
Nomi nal Diame ter	DN4								4mm
	DN6								6mm
	DN10								10mm
	DN15								15mm
	DN20								20mm
	DN25								25mm
	DN32								32mm
	DN40								40mm
	DN50								50mm
Output type	N								DC12~24V power supply, pulse output aviation plug
	N 1								DC12~24V power supply, pulse output Hessman
	F N								DC12~24V power supply, pulse output, waterproof grade IP68
	A								DC24V power supply, 4- 20mA output, no display small blue shell
	A 1								DC24V power supply, 4- 20mA output Hessman connector
	A 2								DC24V power supply, 4- 20mA output, no display gray shell
Connection method	L								Male thread connection
	NL								Female thread connection
Accuracy class	C0								0.2 level
	C1								0.5 level
	C2								1.0 level
	C3								1.5 level
Range type	S								Standard range
	W								Extended range

Body material	S				304 Stainless steel
Impeller material	-				Conventional impeller 2Cr13 (201) material
Pressure Level			N		Regular pressure
Temperature class				-	-20~80°C (not added by default)
				-	- Default length
Note: Conventional threaded connection, default 6.3MPa Conventional flange connection, default 1.6MPa					

(2) Medium temperature: -20~+80°C.

(3) Ambient temperature: -20~+55°C.

(4) Power supply: voltage: 12~24VDC, current: ≤10mA.

(5) Transmission distance: The distance from the sensor to the display instrument can reach 1000m

3. Installation, use and adjustment

(1) Sensor installation

The installation method of the sensor is different according to the specifications, the installation method is shown in Figure 1, Figure 2, and Figure 3, and the installation dimensions are shown in Table 2.

Figure 1: 2000425-DN4~10 Schematic diagram of the structure and installation dimensions of the thread connection sensor

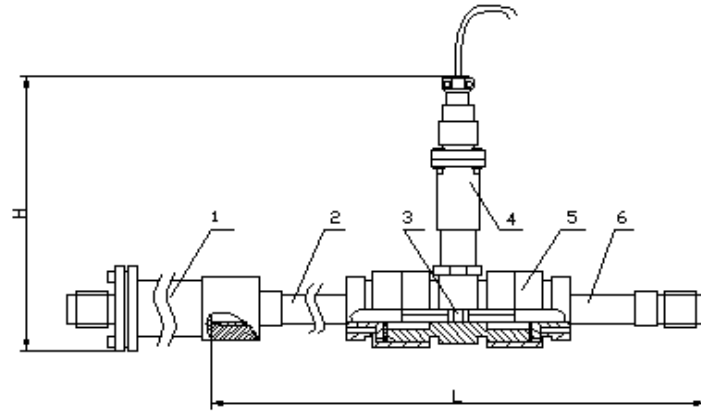

- 1.Filter 2. Front straight pipe section 3. Impeller
4. Pre-amplifier 5. Housing 6. Rear straight pipe section

Figure 2: 2000425-DN15~50 Schematic diagram of the structure and installation dimensions of the threaded connection sensor

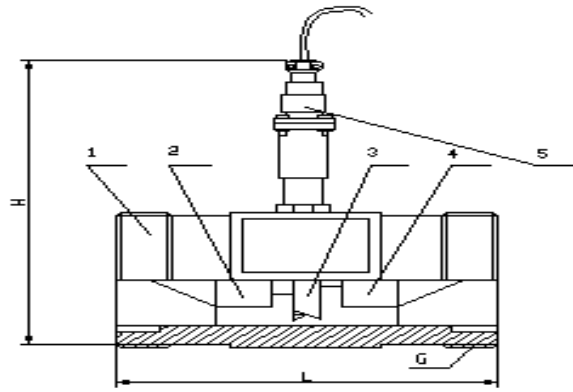

- 1. Housing 2. Front guide 3. Impeller
- 4. Rear guide 5. Pre-amplifier

Figure 3: 2000425-DN15~200 Schematic diagram of the structure and installation dimensions of the threaded connection sensor

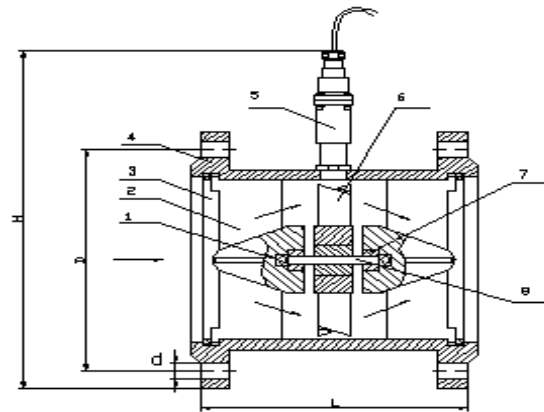

1. Ball bearing
2. Front guide
3. Expander ring
4. Housing
5. Pre-amplifier
6. Impeller
7. Bearing
8. Shaft

(2) 2000425-N Type pulse output wiring instructions: as shown in the figure

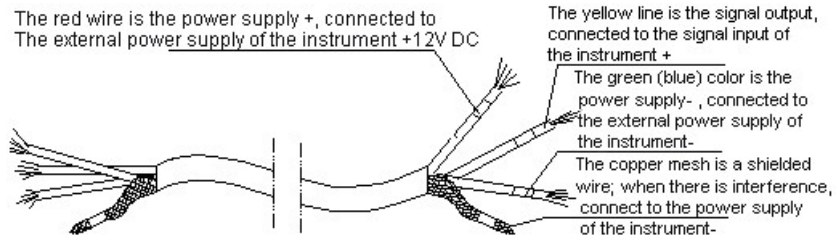

(3) Sensor structure size and range

DN (mm)	Thread connection (mm)		Optional Flange connection (mm)					Clamp connection (mm)		Flow Range(m ³ /h)	
	L	G	L	D1	K	d	n	L	D	Normal	Expand
DN4	225	G1/2						50	50.5	0.04~0.25	0.04~0.4
DN6	225	G1/2						50	50.5	0.1~0.6	0.06~0.6
DN10	345	G1/2						50	50.5	0.2~1.2	0.15~1.5
DN15	75	G1	75	95	65	14	4	100	50.5	0.6~6	0.4~8
DN20	85	G1	85	105	75	14	4	100	50.5	0.8~8	0.45~9
DN25	100	G5/4	100	115	85	14	4	100	50.5	1~10	0.5~10
DN32	140	G3/2	140	140	100	18	4	120	50.5	1.5~15	0.8~15
DN40	140	G2	140	150	110	18	4	140	64	2~20	1~20
DN50	150	G5/2	150	165	125	18	4	150	78	4~40	2~40

The sensor can be installed horizontally or vertically, and the fluid direction must be upward when installed vertically. The liquid should fill the pipe without air bubbles. When installing, the liquid flow direction should be consistent with the direction of the arrow indicating the flow direction on the sensor housing. The upstream end of the sensor should have a straight pipe section of at least 10 times the nominal diameter, and the downstream end should have a straight pipe section of no less than 5 times the nominal diameter. The inner wall should be smooth and clean without defects such as dents, scales, and peeling. The axis of the pipeline of the sensor should be aligned with the axis of the adjacent pipeline, and the gasket used for connection and sealing must not go deep into the inner cavity of the pipeline.

The sensor should be far away from the external electric field and magnetic field, and if necessary, effective shielding measures should be taken to avoid external interference.

In order not to affect the normal delivery of liquid during maintenance, it is recommended to install a bypass pipe at the installation place of the sensor.

When the sensor is installed outside, please do a good job of waterproofing the amplifier and plug. The connection between the sensor and the display instrument is shown in Figure 4.

When the fluid contains impurities, a filter should be installed. The mesh of the filter depends on the flow of impurities, generally 20-60 mesh. When the fluid is mixed with free gas, an air eliminator should be installed. The entire piping system should be well sealed.

Users should fully understand the corrosion of the measured medium, and strictly prevent the sensor from being corroded.

(4) Use and adjustment

- ◆ When in use, the measured liquid should be kept clean and free from impurities such as fibers and particles.

- ◆ When the sensor starts to be used, the sensor should be filled with liquid slowly, and then the outlet valve is opened, and the sensor is strictly prohibited from being impacted by high-speed fluid when it is in an anhydrous state.

- ◆ The maintenance cycle of the sensor is generally half a year.

When overhauling and cleaning, please be careful not to damage the parts in the measuring chamber, especially the impeller. When assembling, please pay attention to the positional relationship between the guide and the impeller.

- ◆ When the sensor is not in use, the internal liquid should be cleaned, and protective sleeves should be added to both ends of the sensor to prevent dust from entering, and then stored in a dry place.

- ◆ When used, the filter should be cleaned regularly. When not in use, the liquid inside should be cleaned. Like the sensor, add a dust cover and store it in a dry place.

- ◆ The transmission cable of the sensor can be laid overhead or buried (iron pipe should be put on when buried.)

- ◆ Before installing the sensor, first connect the wires to the data acquisition instrument, turn on the power supply, blow or manually turn the impeller, and make it rotate quickly to observe whether there is an output, and then install the sensor.

(5) Typical installation

The sensor should be installed in a place convenient for maintenance, where the pipeline is free from vibration, strong electromagnetic interference and thermal radiation. In places where the flow cannot be stopped, a bypass pipe and a reliable cut-off valve (see the above figure) should be installed, and no leakage of

the bypass pipe should be ensured during the measurement.

At the position where the sensor is installed in the newly laid pipeline, connect a short pipe instead of the sensor, and then connect the sensor formally after the "line sweeping" is finished and it is confirmed that the pipeline is clean.

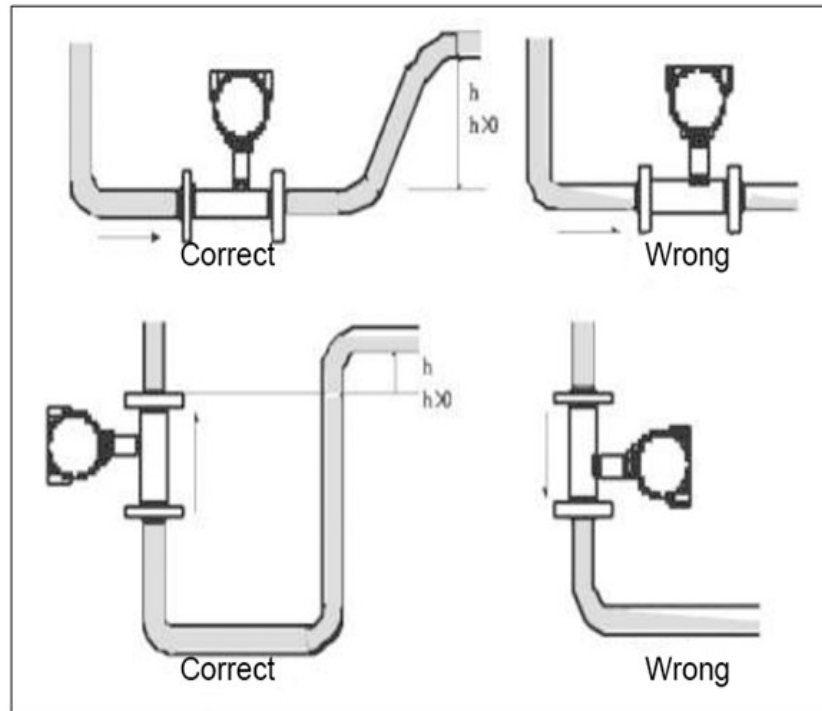

▲ The turbine flow sensor should not be installed near the motor, transformer or other power sources which are easy to cause electromagnetic interference.

▲ Do not install the turbine flow sensor near the inverter or get

power from the inverter distribution cabinet to avoid interference.

▲ The turbine flow sensor should be avoided to be installed on the pipeline with mechanical vibration. If it needs to be installed, Damping measures must be taken, such as installing hose transition, or installing pipeline fixed support points and shockproof pads both upstream and downstream of flowmeter.

▲ The horizontal sensor installation requires that the pipeline should not be tilted visually (generally within 5°), and the verticality deviation of the vertical sensor installation pipeline should also be less than 5°.

▲ The pipeline must be filled with liquid. If the measured liquid contains gas, a getter should be installed at the upstream side of the sensor. The sewage outlet and degasser of the filter and degasser should lead to a safe place.

III . 2000425-A/A1 Turbine Flow Transmitter

The 2000425-A/A1 turbine flow sensor is based on the 2000425 basic turbine flow sensors, adding 24VDC power supply and 4-20mA two-wire current transmission function.

$$\text{Flow calculation formula: } Q = \frac{I - 4}{16} Q_F$$

In the formula: Q—actual flow

Q_F - the upper limit of the range

I - current output

Transmitter supply voltage: DC24V

Type A wiring diagram is as follows:

A(+)
B(-) —Signal output

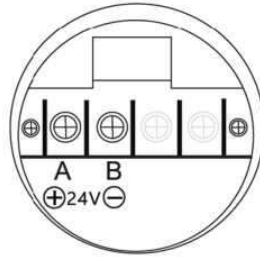

"A" is the "+" terminal of 15~24V power supply

"B" is 4" 20mA current output terminal

"A" is connected to the +24V external power supply, and the current output flows from the "B" terminal to the sampling resistor of the computer or display meter, and then flows back to the "-" terminal of the power supply after passing through the sampling resistor and other loads

Type A1 wiring

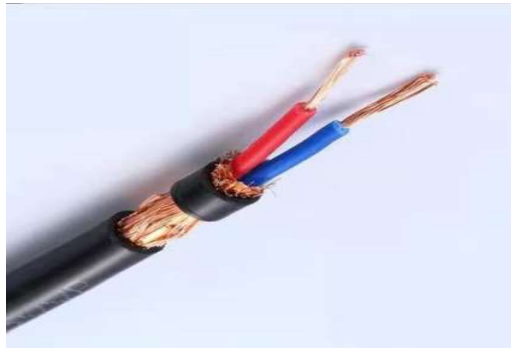

**Red is connected to 24v, blue is connected to signal +, signal -
shorted connected with 0V**

IV. Maintenance

The maintenance cycle should not exceed half a year.

V. Transportation and storage

The sensor should be packed in a strong wooden box or carton, and it is not allowed to move freely in the box. It should be handled with care when handling, and rough loading and unloading is not allowed.

The storage area should meet the following conditions:

1. Rainproof and moisture proof.
2. Not subject to mechanical vibration or impact.
3. Temperature range $-20^{\circ}\text{C}\sim+55^{\circ}\text{C}$.
4. The relative humidity is not more than 80%.
5. There is no corrosive gas in the environment.

VI. Precautions for unpacking

1. After unpacking, check whether the documents and accessories are complete according to the packing list.

Packing documents include: an instruction manual

A product certificate

2. Observe whether the sensor is damaged due to transportation, handle it properly.

3. The user should keep the "certificate of qualification" properly and do not lose it, otherwise the instrument coefficient cannot be set!

VII. Order information

When ordering a turbine flow sensor, the user should pay attention to selecting the appropriate specification according to the nominal diameter of the fluid, working pressure, working temperature, flow range, fluid type and environmental conditions.